

***USING THE SGCP INTERACTIVE
CONTROL PANEL FOR
IP TELEPHONY TESTING***

An introduction
to the new
SGCP Interactive Control Panel
and its use for testing
a VoIP Gateway

Bellcore

© Bell Communications Research
Network Services Integration

Consulting Solution

The purpose of this white paper is to illustrate the flexibility and benefits of the Simple Gateway Control Protocol Interactive Control Panel (S-ICOP) for testing Voice over IP Network Gateways, Announcement Servers, and Internet Call Routing (ICR) node employed in an IP Telephony network architecture. Some relevant test configurations are shown and the generic high-level test categories that can be easily executed using the S-ICOP toolkit are indicated.

INTRODUCTION

The Simple Gateway Control Protocol Interactive Control Panel (S-ICOP) tool is part of the family of the Bellcore Interactive tools created for facilitating the testing of signaling protocol interfaces. It is particularly suitable for testing the SGCP interface of a VoIP Gateway and Announcement Server, it can also be used to simulate any SGCP node in its interaction with an SGCP Internet Call Routing (ICR) node. The ICR node is a new SS7 capable node that contains the intelligence for Internet call routing.

The S-ICOP tool is a Graphical User Interface (GUI) which allows interactive access and control of SGCP Messages. SGCP packets can be created and sent to a System Under Test (SUT) with just a few mouse clicks. All messages sent and received by the application are logged and fully decoded in plain English.

The S-ICOP Panel allows the tester a more efficient and versatile way to test an SGCP interface in both conformance and interoperability test scenarios where it could be used to simulate special features or capabilities.

VOIP GATEWAY TESTING

The S-ICOP panel is particularly suitable for standalone testing of a VoIP Gateway. The following diagrams depict the generic test configurations that can be used.

Figure 1 shows the generic configuration to be used for the VoIP Access Gateway (AG) testing.

This configuration allows executing tests belonging to the following high-level test categories:

- ✓ MF signaling to encapsulated PRI Q.931 conversion
- ✓ PRI Q.931/Q.921 link layer to encapsulated PRI Q.931 bridging
- ✓ SGCP Conformance Testing (tones selection, digit collection, etc.)
- ✓ AG Load and Performance Testing

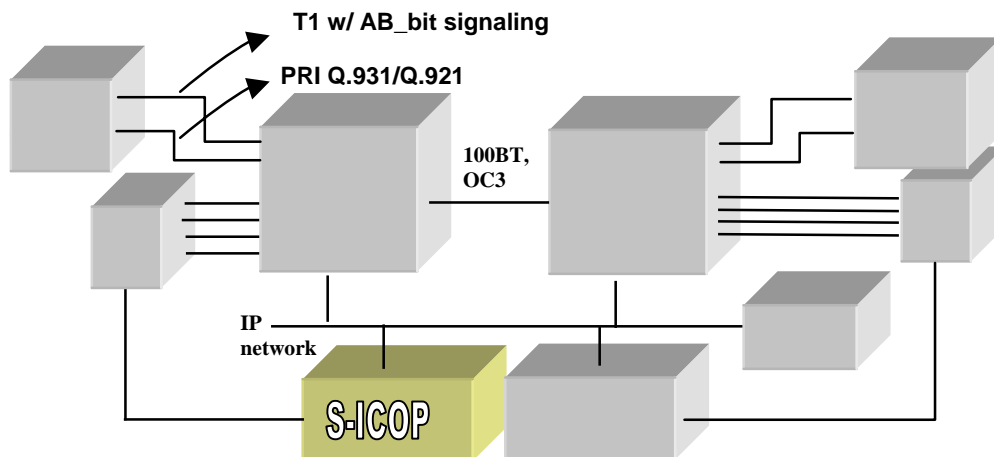

- ✓ Call set-up/tear-down
- ✓ OSS integration

parameters can be conveniently constructed and sent to the SUT for testing purposes.

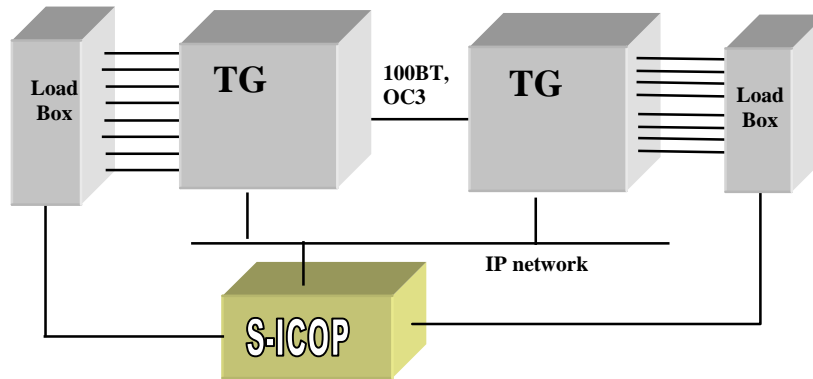

Figure 2 GT2 Test Configuration

Figure 2 depicts the test configuration to be used for testing the VoIP Trunking Gateway (TG). The following high-level test categories can be executed using this test set-up:

- ✓ SGCP Conformance Testing
- ✓ TG Basic Capability Testing
- ✓ TG Load and Performance Analysis
- ✓ TG Interoperability Testing (Multi-vendor Environment)
- ✓ OSS Integration

With minor modification and addition the same configuration can be used to evaluate the impact of the latency delay introduced by the IP network on the perceived voice quality.

In both test scenarios the S-ICOP panel is used to provide a simple emulation of the SGCP ICR node. When used specifically for SGCP conformance testing it allows a tester to verify the conformity to the SGCP requirements in both valid and invalid conditions. With just few click of the mouse the Advanced Message Builder allows to create both valid and invalid messages. Syntactically incorrect SGCP messages, containing for example a parameter that is incorrectly encoded, can be sent to the System Under Test (SUT) to verify the implemented error handling procedure. Analogously, semantically incorrect SGCP messages containing a forbidden set of

ANNOUNCEMENT SERVER TESTING

S-ICOP can be efficiently used for testing of an Announcement Server (AS). Figure 3 shows the generic test configuration.

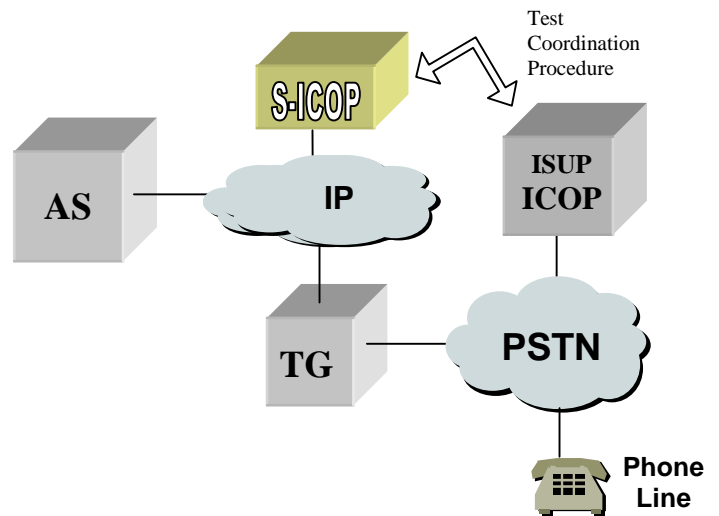

Figure 3 Announcement Server (AS) Test Configuration

In this configuration the ISUP Interactive Control Panel (ISUP ICOP) can be used in coordination with the S-ICOP application in order to set-up a call between the AS and a PSTN user (full ICR node emulation).

The following test categories can be executed in this configuration:

- ✓ Basic Capability Testing
- ✓ Load and performance Analysis
- ✓ Subjective Voice Quality

SGCP ICR NODE TESTING

The S-ICOP application is also suited to perform testing of the SGCP ICR node when real gateway are not available or when in load testing scenarios the number of required gateway make impractical if not

impossible to execute those test in a lab environment.

Figure 4 shows a generic test configuration that can be used for executing the following test categories:

- ✓ Basic Capability analysis
- ✓ Load and Performance Analysis
- ✓ Integration with external systems testing (Billing, OSS, NEDB, etc.)
- ✓ Integration with external services (LNP, Toll-free)
- ✓ Basic Services Testing (911, Operator, Directory Assistance, ...)
- ✓ Telephony Services Testing (CWT, CFW, etc.)

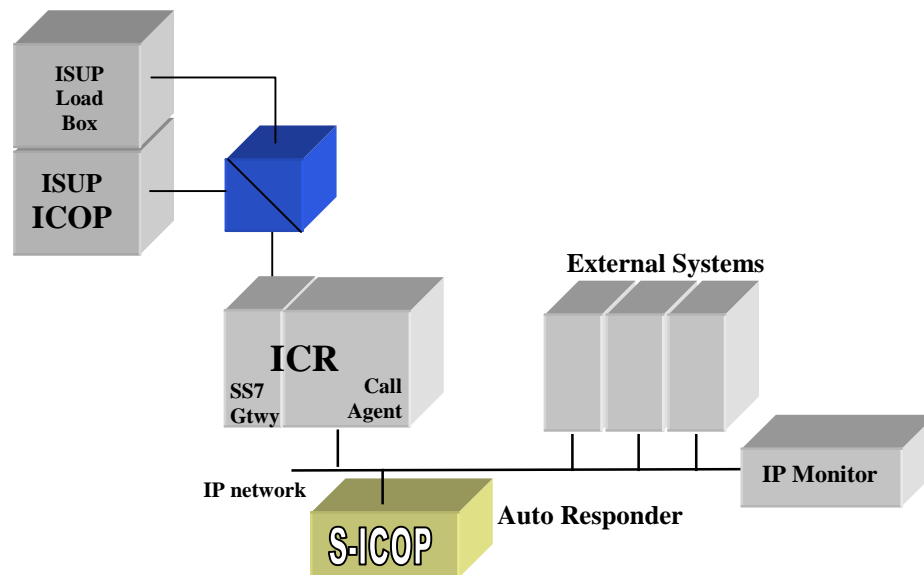

Figure 4 SGCP ICR node Test Configuration

SUMMARY

The S-ICOP application is a versatile interactive toolkit. It can be used in several testing scenarios to facilitate and expedite the execution of VoIP product conformance, interoperability and integration testing.

The S-ICOP can be integrated with other Bellcore interactive (e.g. ISUP ICOP) to allow the complete testing of SGCP Network Elements earlier in their development cycle. The S-ICOP facilitates the execution of invalid behavior testing. It can facilitate the implementation of the Simple Gateway Control Interface (SGCI).



Bellcore can help:

Network Services Integration

Clinton M. Hamilton, Director

1-732-758-3055

chamilto@notes.cc.bellcore.com

Or, discover Bellcore on the Internet:

<http://www.bellcore.com>